



EDGE[®]

AUTOMATION PVT. LTD.

— Committed to Excellence —

www.edgeautomation.co.in

HMI CABINETS



HMI CABINETS

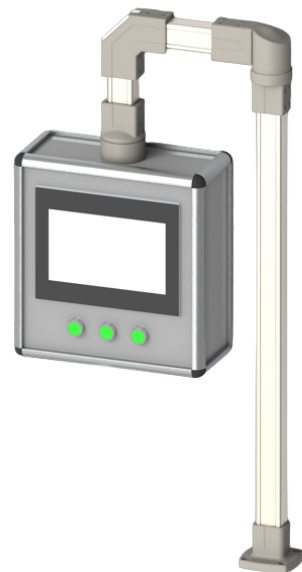
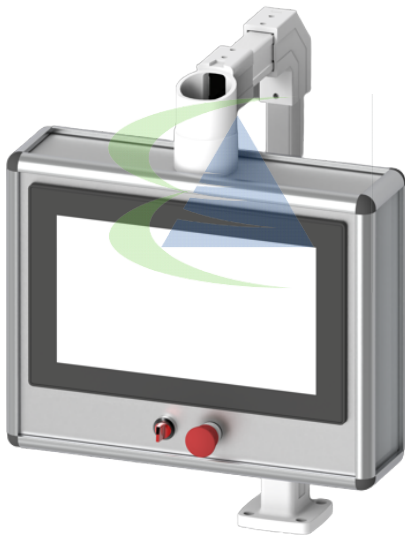



EDGE[®]
AUTOMATION PVT. LTD.
— Committed to Excellence —

Console



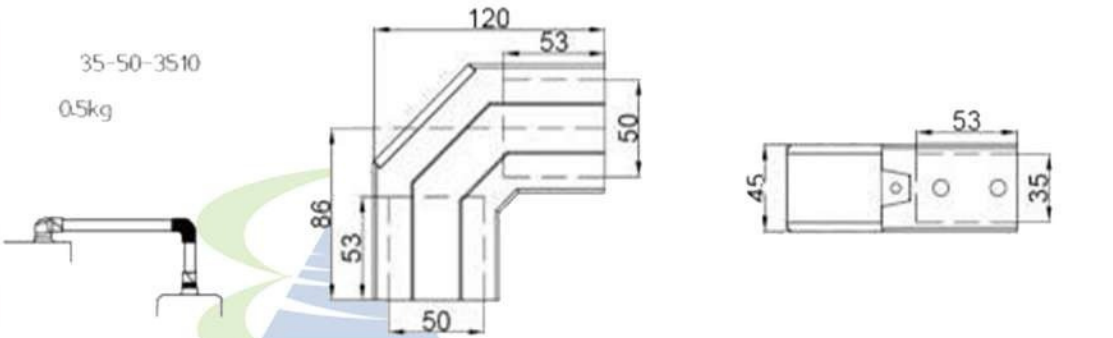
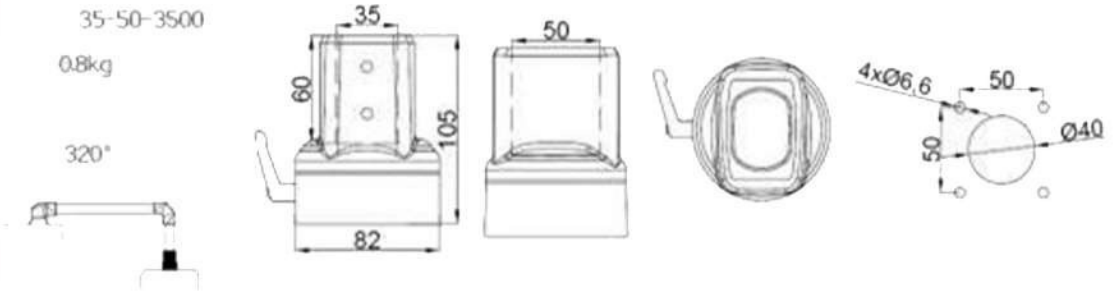

EDGE Automation

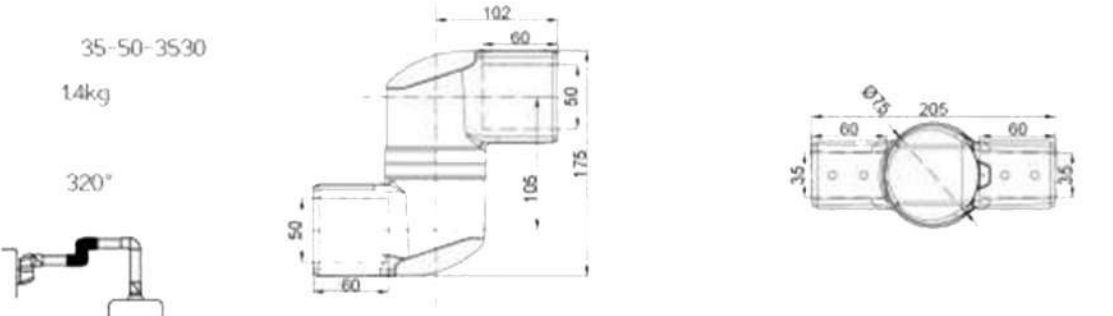
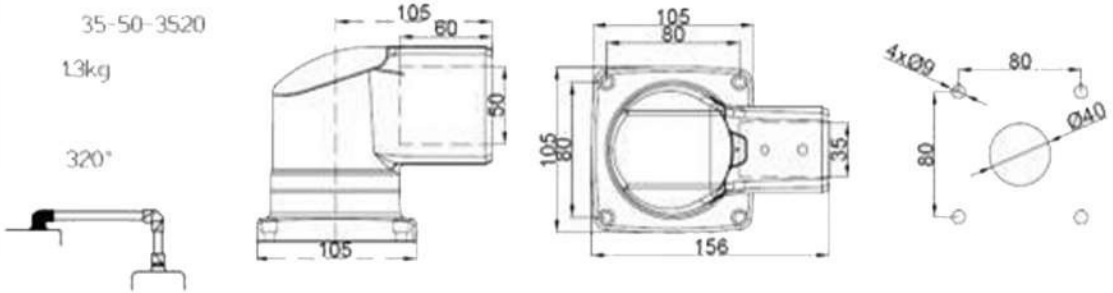

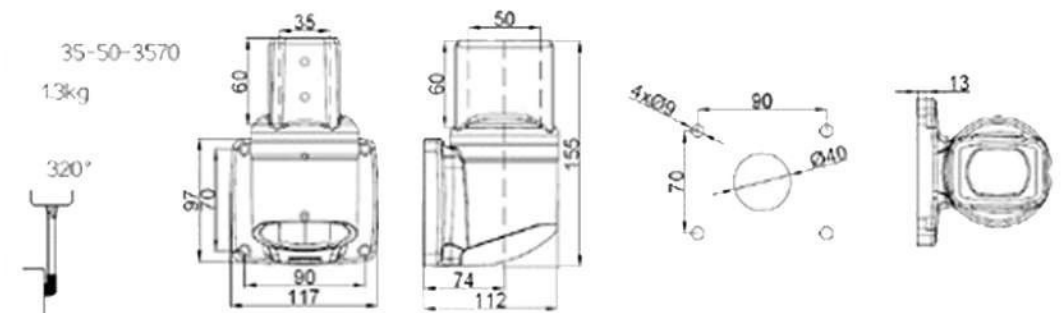
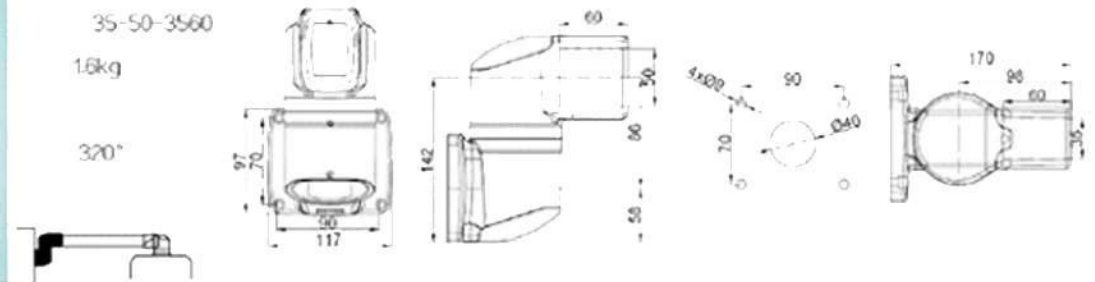
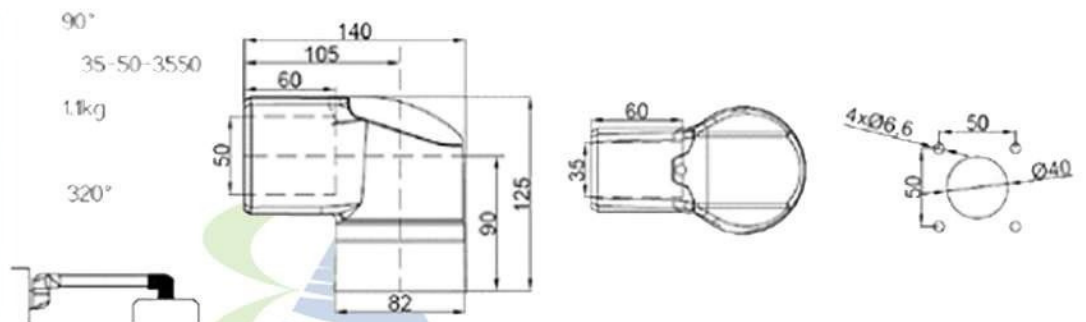
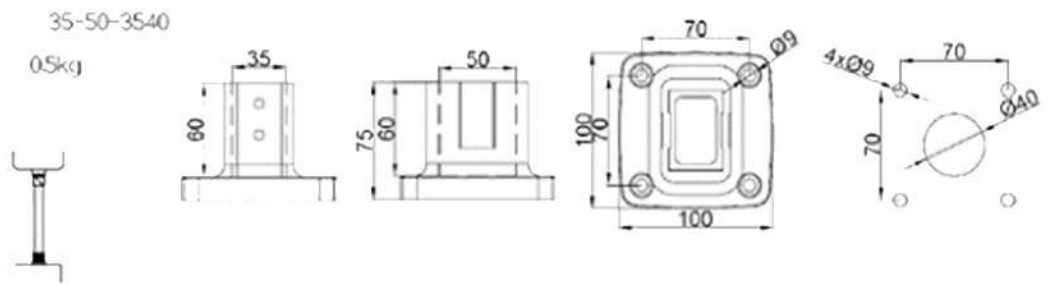

EDGE Automation



35-50-3580
0.95kg

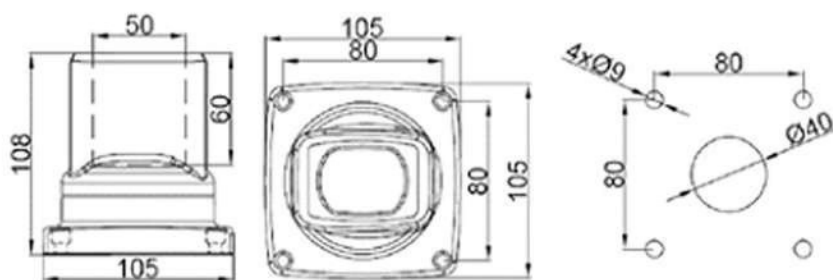

35-50-3590
1.1kg

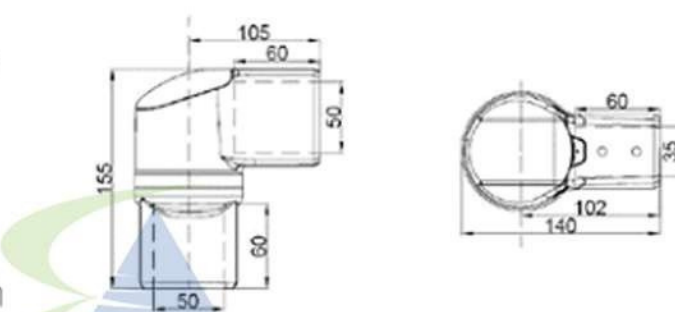
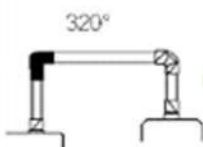

EDGE Automation



35-50-3900
1.1kg

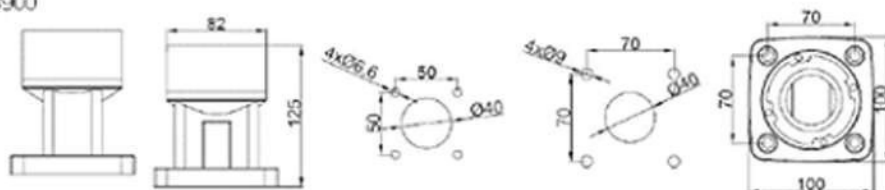

18kg/m

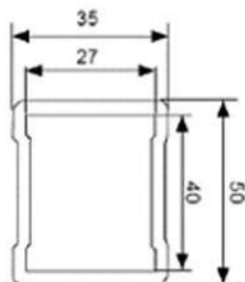

0.25m	35-50-250
0.5m	35-50-500
1m	35-50-1000
15m	35-50-1500

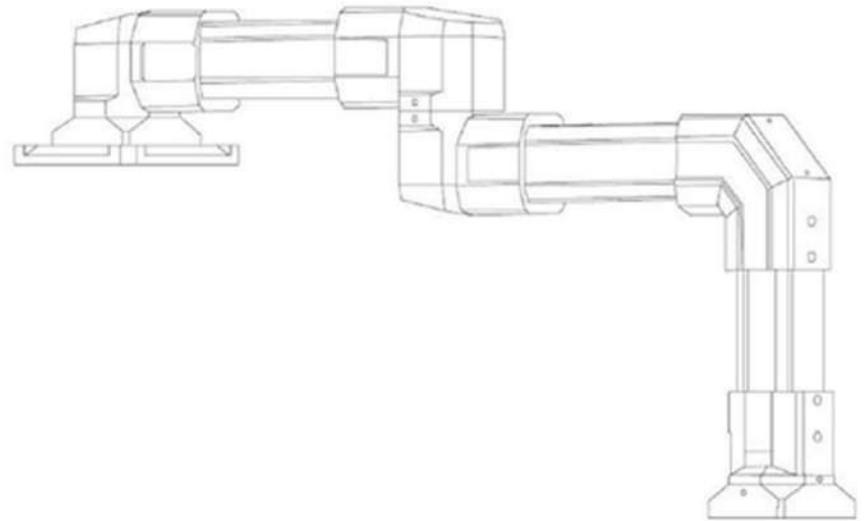

46-60-6600
0.92kg

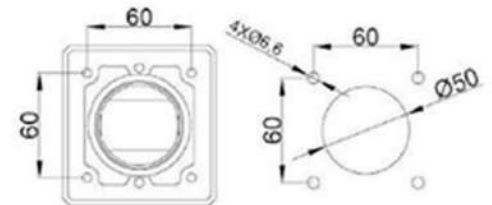
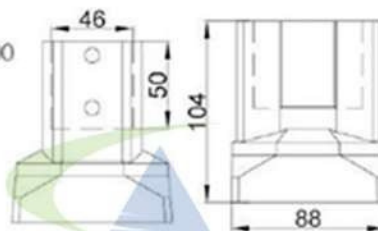
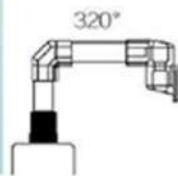

EDGE Automation



46-60-6610
0.8kg

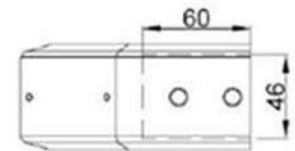
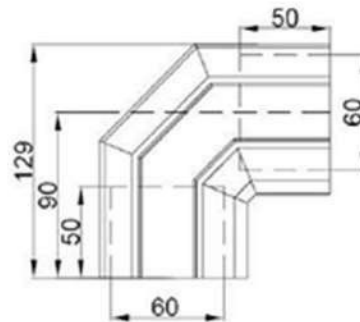
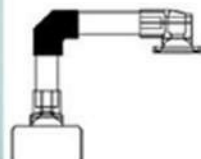

46-60-6620
1.9kg

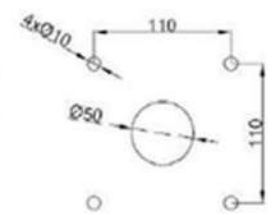
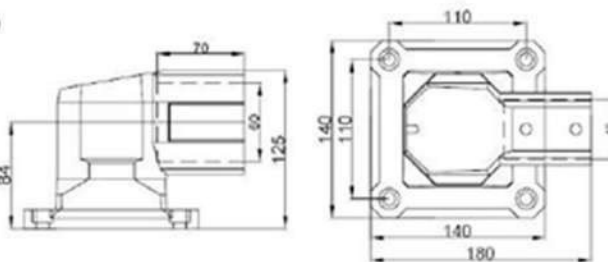
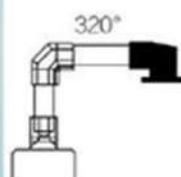

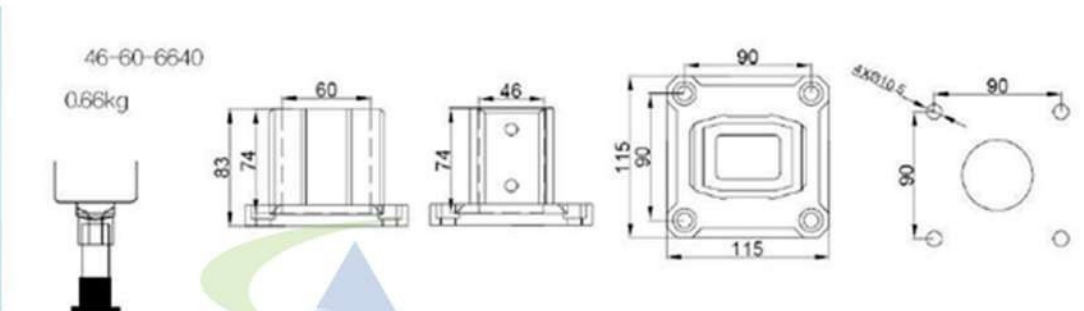
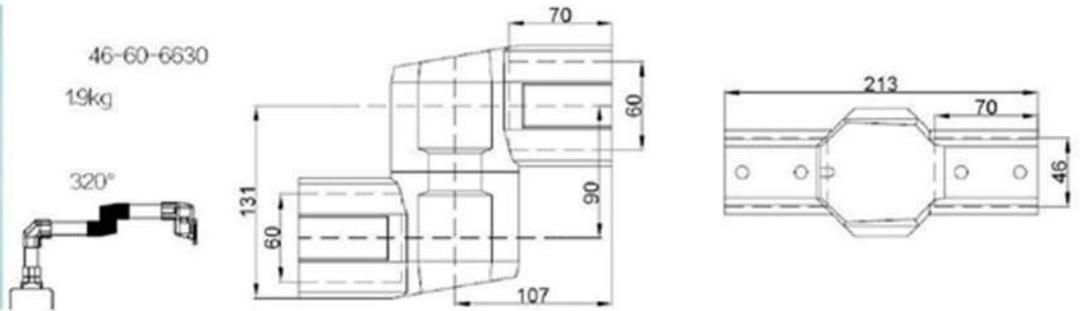

EDGE Automation

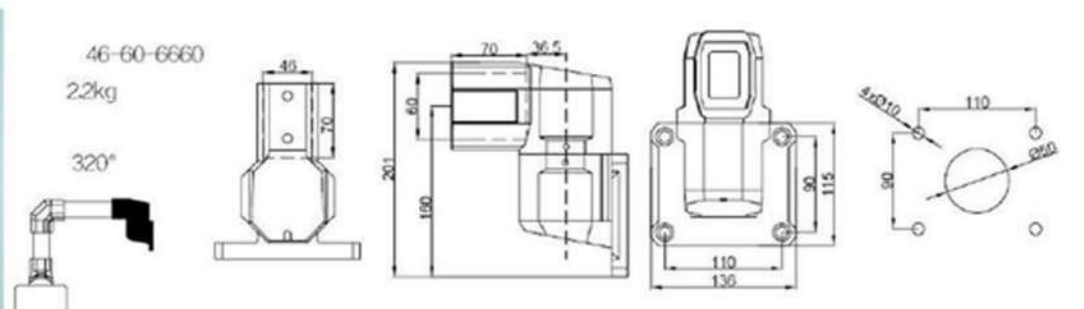
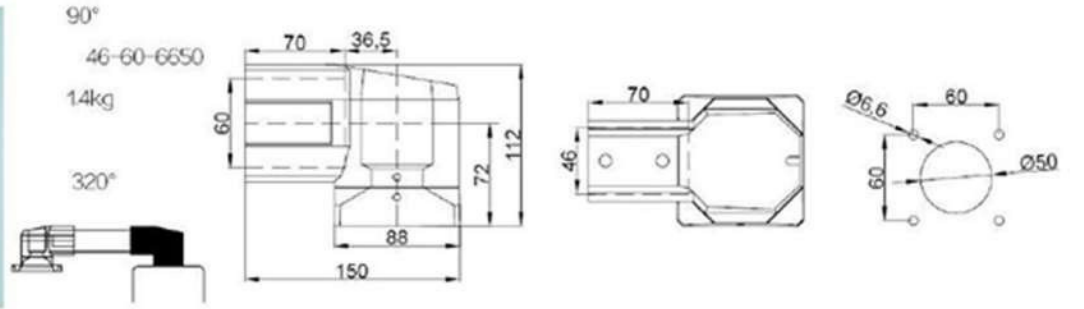



46-60-6670
1.8kg

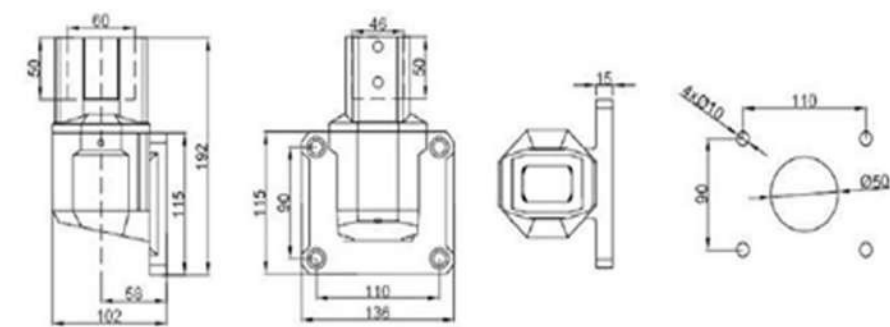
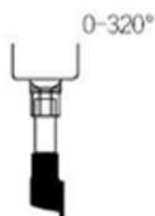

46-60-6680
1.5kg

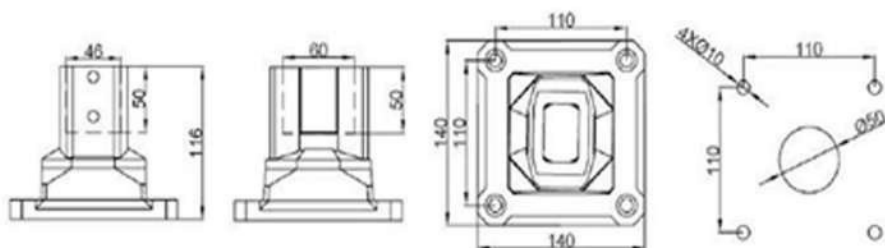
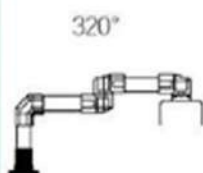

46-60-6690
1.5kg

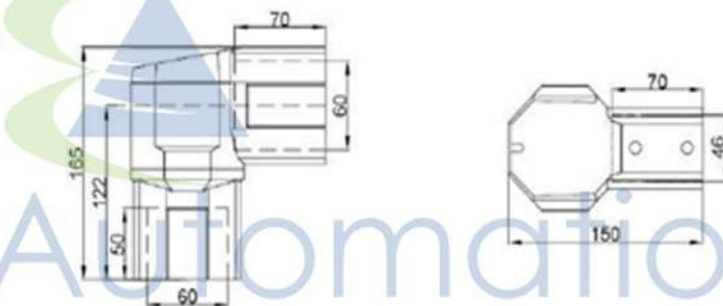
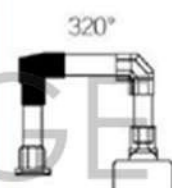

46-60-4900
1.4kg

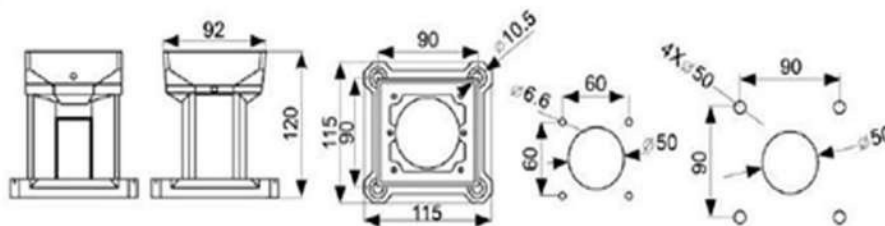

46-60
2.7kg/m

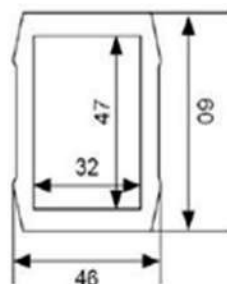

0.25m	46-60-250
0.5m	46-60-500
1m	46-60-1000
1.5m	46-60-1500

8CONSOLE-50-65-270 (DV)



Product Name:	Vertical Wall Seat
Part Number:	50-65-270
Weight:	1.2 Kgs.
Material:	Die-Cast Aluminum Alloy
Rotatable:	0 - 320°

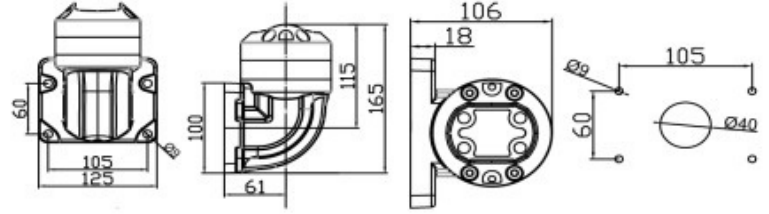

9CONSOLE-50-65-280 (DV)

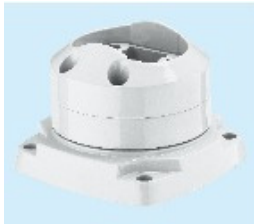

Product Name:	Base
Part Number:	50-65-280
Weight:	0.9 Kgs.
Material:	Die-Cast Aluminum Alloy
Rotatable:	0 - 320°

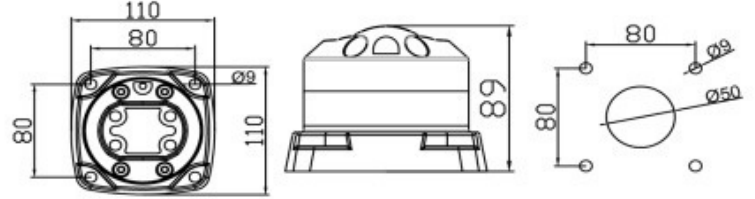

10CONSOLE-50-65-290 (DV)



Product Name:	Rotating Corner
Part Number:	50-65-290
Weight:	0.9 Kgs.
Material:	Die-Cast Aluminum Alloy
Rotatable:	0 - 320°

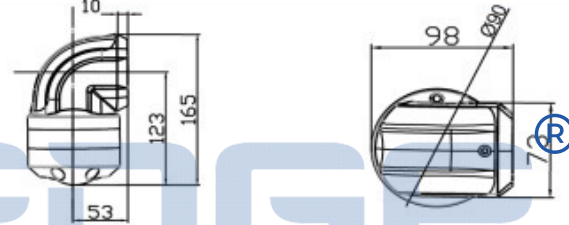

11CONSOLE-50-65-4900 (DV)



Product Name:	Rotating Box Base
Part Number:	50-65-4900
Weight:	0.8 Kgs.
Material:	Die-Cast Aluminum Alloy
Rotatable:	0 - 320°

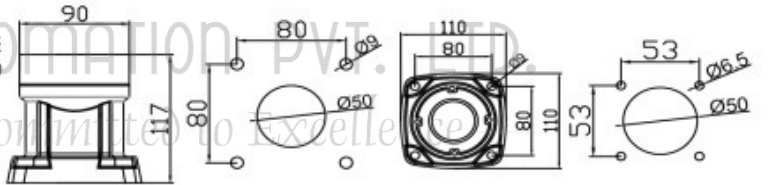

12CONSOLE-50-65-Pipe (DV)



Product Name:	Connecting Pipe
Part Number:	50-65
Weight:	2.2 Kg/Mtr
Material:	Die-Cast Aluminum Alloy

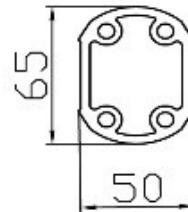

13CONSOLE-50-65-2091 (DV)



Product Name:	Narrow Box Connector
Part Number:	50-65-2091
Weight:	0.5 Kgs.
Material:	Die-Cast Aluminum Alloy
Rotatable:	0 - 320°

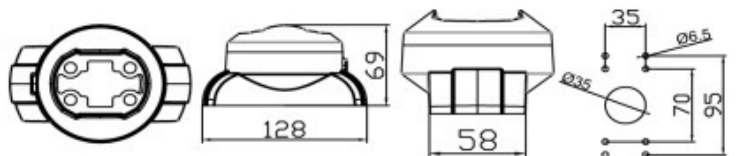

Console Part Assembly 50-65 Series

1CONSOLE-50-65-2090 (DV)



Product Name:	Box Connector
Part Number:	50-65-2090
Weight:	0.6 Kgs.
Material:	Die-Cast Aluminum Alloy
Rotatable:	0 - 320°

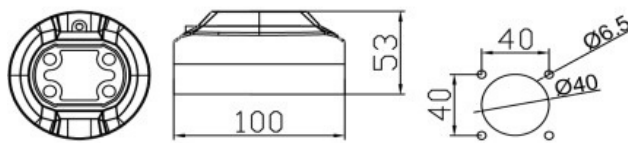

2CONSOLE-50-65-210 (DV)



Product Name:	Corner
Part Number:	50-65-210
Weight:	0.4 Kgs.
Material:	Die-Cast Aluminum Alloy



3CONSOLE-50-65-220 (DV)



Product Name:	Top Seat
Part Number:	50-65-220
Weight:	0.9 Kgs.
Material:	Die-Cast Aluminum Alloy
Rotatable:	0 - 320°

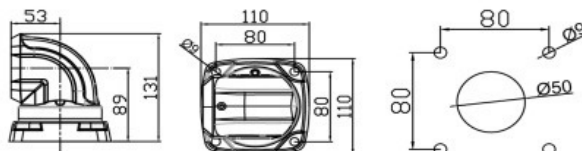

4CONSOLE-50-65-230 (DV)



Product Name:	Intermediate Connector
Part Number:	50-65-230
Weight:	1 Kgs.
Material:	Die-Cast Aluminum Alloy
Rotatable:	0 - 320°

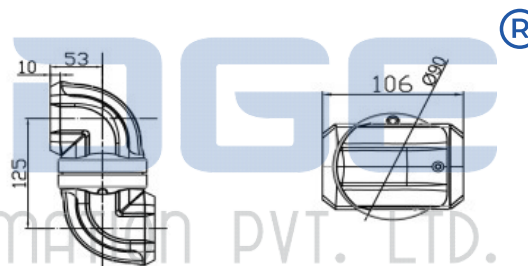

5CONSOLE-50-65-240 (DV)



Product Name:	Fixed Base
Part Number:	50-65-240
Weight:	0.4 Kgs.
Material:	Die-Cast Aluminum Alloy

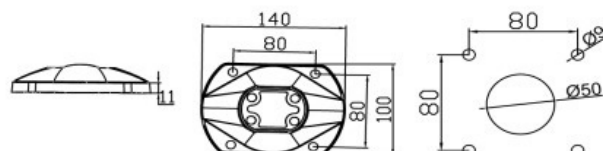

6CONSOLE-50-65-250 (DV)



Product Name:	90° Box Connector
Part Number:	50-65-250
Weight:	0.8 Kgs.
Material:	Die-Cast Aluminum Alloy
Rotatable:	0 - 320°

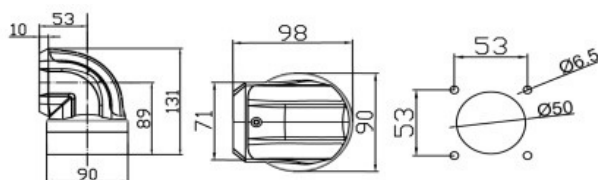

7CONSOLE-50-65-260 (DV)



Product Name:	Horizontal Wall Seat 50-
Part Number:	65-260
Weight:	1.3 Kgs.
Material:	Die-Cast Aluminum Alloy
Rotatable:	0 - 320°

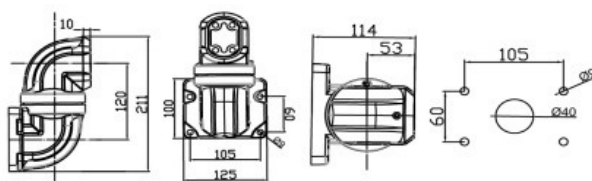

EDGE
AUTOMATION PVT. LTD.
Committed to Excellence



55-75-8090

18kg

320°

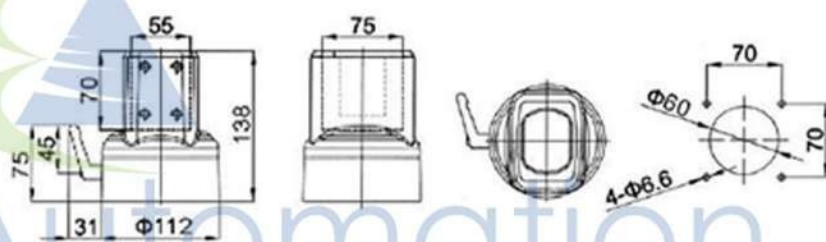
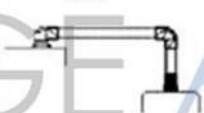

55-75-8810

14kg

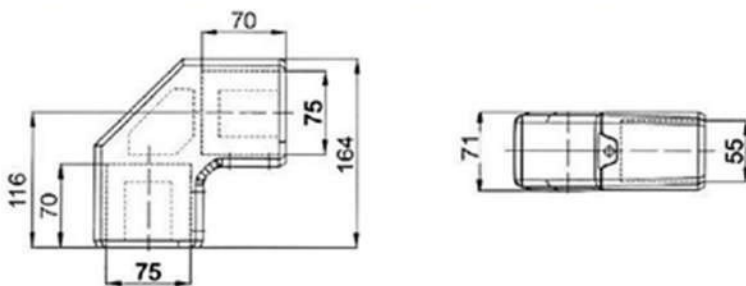

55-75-8820

26kg

320°

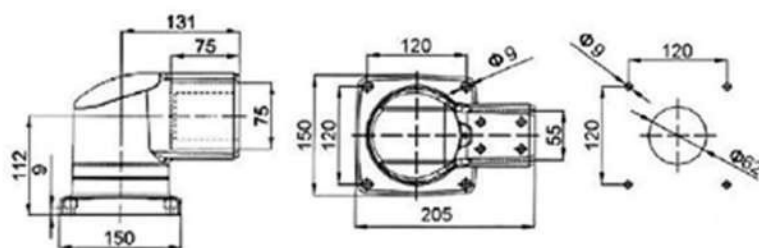



55-75-8830

3.3kg

320°

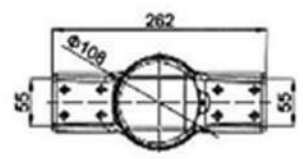
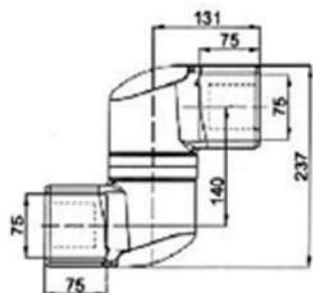
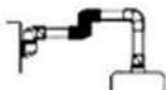

55-75-8840

0.9kg



90°

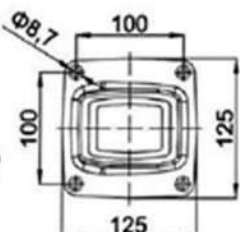
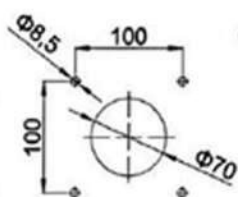
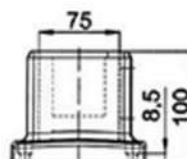
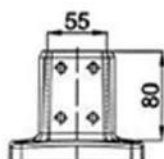

55-75-8850

2.4kg

320°

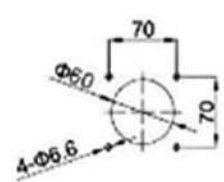
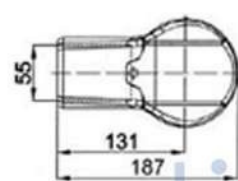
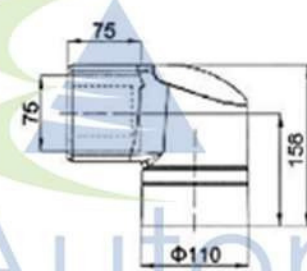

55-75-8860

3.4kg

320°

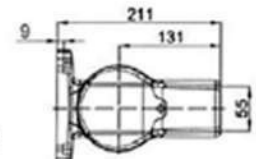
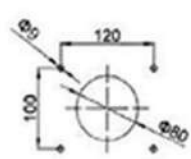
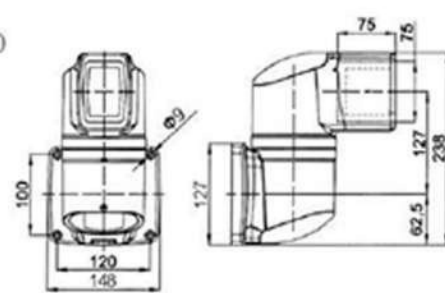

55-75-8870

2.6kg

320°

